

REIBEN & SENKEN VHM REAMING & COUNTERSINKING VHM (SOLID CARBIDE)





	ARTIKEL-BESCHREIBUNG ARTICLE-DESCRIPTION	ARTIKEL-NR. ARTICLE-NO.	SEITE PAGE	STAHL	INOX	NE-METALLE	GUSS	TITAN	HRC	GRAPHIT	
	VHM	E.5615.0	2	✓	✓	✓	✓				
	VHM	E.5616.0	2	✓	✓	✓	✓				
	VHM	E.5617.0	2	✓	✓	✓	✓				
	VHM	E.5604.0	3	✓	✓	✓	✓				
	VHM  Blue Cut	E.5603.1	3	✓	✓	✓	✓		✓		
	VHM  Blue Cut	E.5612.1	4	✓	✓	✓	✓				
	VHM  Blue Cut	E.5613.1	4	✓	✓	✓	✓		✓		
	VHM  Blue Cut	E.5614.1	4	✓	✓	✓	✓		✓		
	VHM  Blue Cut	E.5636.1	5	✓	✓	✓	✓				
	VHM  Blue Cut	E.5637.1	5	✓	✓	✓	✓				
	VHM TOL. H 7 Blue Cut	E.5635.1	5	✓		✓	✓				✓
	VHM TOL. H 7	E.5605.0	6	✓	✓	✓	✓	✓			
	VHM TOL. 0/+0,005	E.5619.0	7	✓	✓	✓	✓				
	VHM TOL. H 7 Blue Cut SPEZIAL BESCHICHTUNG COATING	E.5624.1	8	✓			✓		✓		✓
	VHM TOL. 0/+0,005 Blue Cut SPEZIAL BESCHICHTUNG COATING	E.5619K.1	8	✓	✓	✓	✓		✓		✓
	VHM TOL. 0/+0,005	E.5622.0	9	✓	✓	✓	✓				
	VHM TOL. H 7	E.5632.0	10	✓	✓	✓	✓				
	VHM TOL. 0/+0,005	E.5620.0	10	✓	✓	✓	✓				
	VHM TOL. H 7	E.5618.0	11	✓	✓	✓	✓				
	VHM TOL. H 7 Blue Cut	E.5634.1	12	✓			✓		✓		✓
	VHM TOL. 0/+0,005 Blue Cut	E.5625.1	12	✓			✓		✓		✓
	VHM TOL. H 7 Blue Cut	E.5631.1	13	✓	✓	✓	✓		✓		
	CERMET TOL. H 7	E.5626.0	14	✓		✓	✓	✓	✓		

Gewindbohrer	1
Bohren HSSE	2
Bohren VHM	3
Reiben HSSE	4
Reiben VHM	5
Frässtifte VHM	6
Fräsen VHM	7
WP-Werkzeuge	8
Fräsen HSSE	9
Sägen	10
Lehren	11
Nachschleifen	12
Sonstiges	13

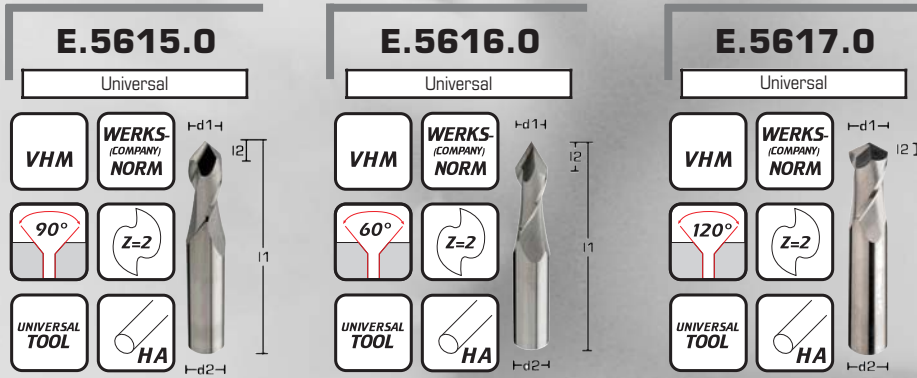
Die angegebenen Einsatzgebiete sind Richtlinien. Die genauen Einsatzdaten finden Sie im jeweiligen Artikel!  
 The indicated operational areas are estimated guide lines. The exact dates of use please find at the specified articles!





-  Solid carbide CNC-8-fold tools
-  Fazowniki 8-funkcyjne z węgla spiekanego do maszyn CNC
-  Svasatore MD per CNC
-  Herramienta metal duro para 8 aplicaciones CNC

Artikel-Nr. Article-No.				E.5615.0	E.5616.0	E.5617.0
d1	l2	l1	d2	€ Stück piece	€ Stück piece	€ Stück piece
0,50	1,0	38	3,0	29,00	38,00	
0,60	1,2	38	3,0	29,00		
0,70	1,4	38	3,0	29,00		
0,80	1,6	38	3,0	29,00		
0,90	1,8	38	3,0	29,00		
1,00	2,0	38	3,0	29,00	36,00	29,00
1,20	2,4	38	3,0	29,00		
1,40	2,8	38	3,0	29,00		
1,50	3,0	38	3,0	29,00	36,00	29,00
1,80	3,6	38	3,0	29,00		
2,00	4,0	38	3,0	29,00	36,00	29,00
2,50	5,0	38	3,0	29,00	36,00	29,00
3,00	6,0	50	4,0	24,50	29,00	24,00
4,00	8,0	50	5,0	25,80	31,00	25,00
5,00	10,0	50	6,0	27,00	33,00	27,00
6,00	12,0	60	8,0	33,20	39,00	31,00
8,00	16,0	70	10,0	42,00	54,00	45,00
10,00	18,0	70	12,0	53,00	68,00	57,00
12,00	20,0	70	12,0	55,00	70,00	58,00
16,00	26,0	80	16,0	78,00	98,00	78,00
20,00	32,0	100	20,0	130,00	170,00	134,00

# 1

Werkzeug...  
Tool ...

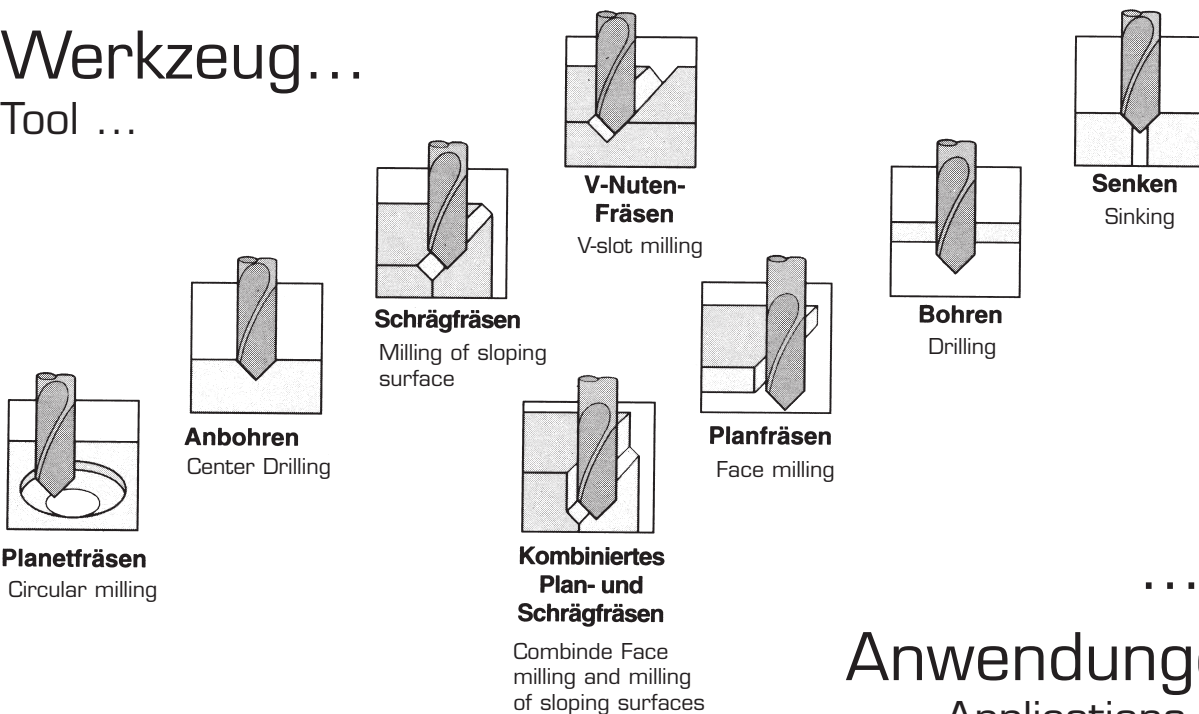





... 8

Anwendungen  
Applications

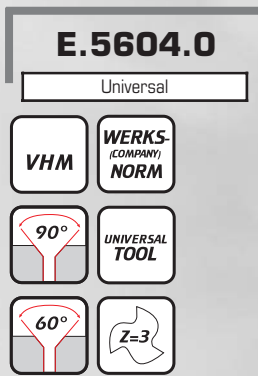
- 1 Gewindbohrer
- 2 Bohren HSSE
- 3 Bohren VHM
- 4 Reiben HSSE
- 5 Reiben VHM
- 6 Frässtifte VHM
- 7 Fräsen VHM
- 8 WP-Werkzeuge
- 9 Fräsen HSSE
- 10 Sägen
- 11 Lehren
- 12 Nachschleifen
- 13 Sonstiges

## VHM-Kombi-Kegelsenker 60°/90°





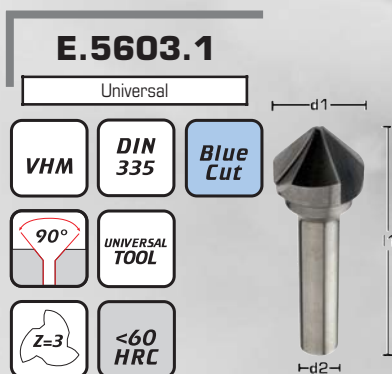

-  Solid carbide countersink 60°/90°
-  Pogłębiacze trzyostrzowe 60°/90° z węglika spiekanego wg normy zakładowej
-  Svasatore in MD combinati 60°/90°
-  Avellanador cónico combi 60°/90° en metal duro integral

Artikel-Nr. Article-No.			<b>E.5604.0</b>
d1	l1	d2	€ Stück piece
2,00	60	6,0	<b>20,00</b>
2,00	70	8,0	<b>31,00</b>
2,00	75	10,0	<b>34,00</b>
2,00	75	12,0	<b>48,00</b>

## VHM-Kegelsenker



-  Solid carbide countersink
-  Pogłębiacze trzyostrzowe 90° z węglika spiekanego wg DIN 335
-  Svasatori in MD
-  Avellanador cónico en metal duro integral

Artikel-Nr. Article-No.			<b>E.5603.1</b>
d1	l1	d2 h9	€ Stück piece
4,30	40	4,0	<b>36,00</b>
5,30	40	4,0	<b>36,00</b>
6,30	45	5,0	<b>36,00</b>
8,30	50	6,0	<b>45,00</b>
10,40	50	6,0	<b>53,00</b>
12,40	56	8,0	<b>58,00</b>
16,50	60	10,0	<b>65,00</b>
20,50	63	10,0	<b>87,00</b>
25,00	67	10,0	<b>104,00</b>
31,00	67	10,0	<b>169,00</b>

## VHM-Vor-/Rückwärtsentgrater 45°

**E.5612.1**

Universal

VHM WERKS (COMPANY) NORM

45° 45° Blue Cut

UNIVERSAL TOOL

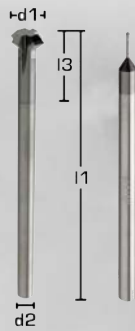

- Solid carbide forwards/backwards deburring tool 45°
- Fazowniki z węgla spiekane 45° od czoła i od spodu, wg normy zakładowej
- Svasatori per interni 45°
- Rebabador 45° hacia delante y atrás en metal duro integral

Artikel-Nr. Article-No.							E.5612.1
d1	l3	Schneidenbreite cutting width	l1	Hals neck	d2	Zähne flutes	€ Stück piece
1,80	9	1,2	100	1,2 x 8	6,0	3	42,00
2,80	10	1,2	100	2,0 x 8	6,0	3	42,00
4,00	13	2,0	100	2,0 x 10	6,0	4	42,00
6,00	19	2,0	100	4 x 15	6,0	4	45,00
8,00	60	2,0	100	6	6,0	4	57,00
10,00	60	4,0	100	6	6,0	4	69,00
12,00	60	4,0	100	6	6,0	4	82,00
16,00	60	8,0	100	10	10,0	4	110,00

## VHM-Entgrater

**E.5613.1**

Universal

VHM WERKS (COMPANY) NORM UNIVERSAL TOOL

60° Blue Cut ≤65 HRC

HRC HB



**E.5614.1**

Universal

VHM WERKS (COMPANY) NORM UNIVERSAL TOOL

90° Blue Cut ≤65 HRC

HRC HB







- Solid carbide deburring tool
- Fazowniki 60/90° z węgla spiekane do materiałów utwardzanych do 65HRC
- Svasatori frese in MD
- Rebabador en metal duro integral

Artikel-Nr. Article-No.				E.5613.1	E.5614.1
d1 h6	l1	d2	Zähne flutes	€ Stück piece	€ Stück piece
1,00	38	3	3		16,00
2,00	38	3	3		16,00
3,00	38	3	3		16,00
4,00	54	4	4	15,00	15,00
6,00	57	6	4	18,00	18,00
8,00	63	8	5	22,00	22,00
10,00	72	10	6	26,50	26,50
12,00	83	12	6	39,00	39,00
16,00	92	16	6	58,00	58,00
20,00	104	20	6	84,00	84,00

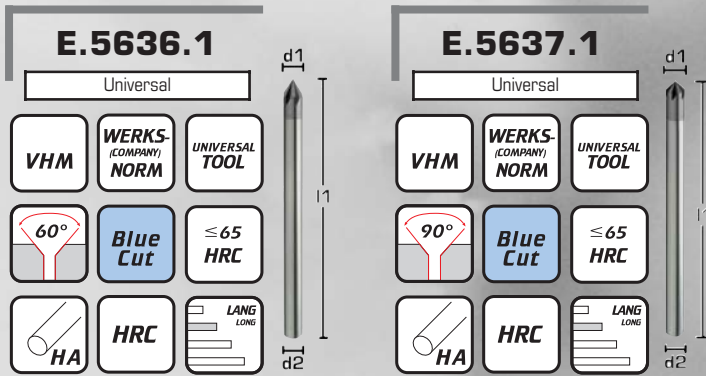
- Gewindebohrer 1
- Bohren HSSE 2
- Bohren VHM 3
- Reiben HSSE 4
- Reiben VHM 5
- Frässtifte VHM 6
- Fräsen VHM 7
- WP-Werkzeuge 8
- Fräsen HSSE 9
- Sägen 10
- Lehren 11
- Nachschleifen 12
- Sonstiges 13

## VHM-Entgrater lang





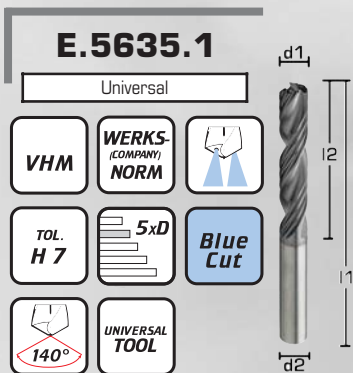

-  Solid carbide deburring tool long
-  Fazowniki długie 60°/90° z węglika spiekane go do materiałów utwardzanych do 65HRC
-  Svasatori frese in MD, serie lunga
-  Rebabador en metal duro integral, serie larga

Artikel-Nr. Article-No.				E.5636.1 € Stück piece	E.5637.1 € Stück piece
d1 h6	l1	d2	Zähne flutes		
4,00	100	4	4	26,50	26,50
6,00	110	6	4	38,00	38,00
8,00	150	8	5	56,00	56,00
10,00	150	10	6	70,00	70,00
12,00	150	12	6	86,00	86,00
16,00	150	16	6	142,00	142,00

## VHM-Bohrreibahnen mit Innenkühlung



-  Solid carbide drill reamers with internal coolant
-  Wiertło-rozwiertaki z węglika spiekane go z chłodzeniem wewnętrznym
-  Punte alesatori MD con fori lubrificanti
-  Broca escariador con refrigeración interior metal duro integral

Artikel-Nr. Article-No.					E.5635.1 € Stück piece
d1 H7	l2	l1	d2 h6	Zähne flutes	
3,00	28	66	6,0	2 / 4	
4,00	36	74	6,0	2 / 4	
5,00	44	82	6,0	2 / 4	
6,00	44	82	6,0	2 / 4	Auf Anfrage
8,00	53	91	8,0	2 / 4	
10,00	61	103	10,0	2 / 4	on demand
12,00	71	118	12,0	2 / 4	
14,00	77	124	14,0	2 / 4	
16,00	83	133	16,0	2 / 4	

Zwischenmaße auf Anfrage Intermediate sizes on demand

Bohrungsuntermaßtabelle für Reibahnen Prehole diameter chart for reamers:

< $\varnothing$ 1 mm	> $\varnothing$ 10 mm	> $\varnothing$ 20	> $\varnothing$ 30	< $\varnothing$ 30
- 0,10	- 0,20	- 0,25	- 0,30	- 0,40

## E.5605.0

Universal





VHM

ähnl.  
DIN  
8089

TOL.  
H 7

FORM  
B



-  Solid carbide machine reamers short
-  Rozwiertaki maszynowe krótkie z węgliką spiekanego
-  Alesatori a macchina MD serie corta
-  Escariador de máquina en metal duro integral, serie corta

Artikel-Nr. Article-No.					E.5605.0
d1 H7	l2	l1	d2 h6	Zähne flutes	€ Stück piece
3,00	20	56	2,5	6	31,00
3,20	20	56	2,8	6	35,00
3,50	20	56	3,0	6	35,00
4,00	20	56	3,6	6	36,00
4,50	22	63	4,0	6	42,00
5,00	22	63	4,0	6	45,00
5,50	22	63	5,0	6	47,00
6,00	22	63	5,0	6	48,00
6,50	22	63	5,0	6	51,00
7,00	20	71	6,3	6	57,00
7,50	20	71	6,3	6	60,00
8,00	20	71	6,3	6	60,00
8,50	20	71	6,3	6	69,00
9,00	22	71	8,0	6	69,00
9,50	22	71	8,0	6	72,00
10,00	22	71	8,0	6	72,00
11,00	22	80	10,0	6	91,00
12,00	22	80	10,0	6	100,00
13,00	20	80	10,0	6	133,00
14,00	20	90	12,5	8	151,00
15,00	20	90	12,5	8	168,00
16,00	20	90	12,5	8	208,00
17,00	22	90	12,5	8	231,00
18,00	22	100	16,0	8	247,00
19,00	22	100	16,0	8	259,00
20,00	22	100	16,0	8	298,00

- Gewindebohrer 1
- Bohren HSSE 2
- Bohren VHM 3
- Reiben HSSE 4
- Reiben VHM 5
- Frässtifte VHM 6
- Fräsen VHM 7
- WP-Werkzeuge 8
- Fräsen HSSE 9
- Sägen 10
- Lehren 11
- Nachschleifen 12
- Sonstiges 13

Bohrungsuntermaßtabelle für Reibahlen *Prehole diameter chart for reamers:*

< ø 1 mm	> ø 10 mm	> ø 20	> ø 30	< ø 30
- 0,10	- 0,20	- 0,25	- 0,30	- 0,40



Solid carbide machine reamers short

Rozwiertaki maszynowe krótkie z węgliką spiekanego

Alesatori MD, serie corta

Escariador de máquina en metal duro integral, serie corta

\* = ab Ø 3,0 mm Zähnezahl 6

\* = starting from Ø 3,0 mm 6 flutes

Lieferzeit: 2 Arbeitstage

Delivery time: 2 working days

Artikel-Nr. Article-No.						E.5619.0
d1 0/+0,005	l2	l3	l1	d2	Zähne flutes	€ Stück piece
0,10 - 0,19	5	10	35	1,5	4	78,00
0,20 - 0,29	5	10	35	1,5	4	71,00
0,30 - 0,47	5	10	35	1,5	4	64,00
0,48 - 0,53	5	10	35	1,5	4	64,00
0,54 - 0,59	5	10	35	1,5	4	62,00
0,60 - 0,69	6	12	35	1,5	4	58,00
0,70 - 0,79	6	12	35	1,5	4	50,00
0,80 - 0,90	6	15	35	1,5	4	43,00
0,91 - 1,00	8	15	35	1,5	4	42,00
1,01 - 1,20	10	17	35	1,5	4	39,00
1,21 - 1,50	12	23	40	1,5	4	37,00
1,51 - 2,00	16	28	45	2,0	4	35,00
2,01 - 2,40	18	31	50	2,0 - 3,0	4	35,00
2,41 - 2,70	20	34	55	3,0	4	35,00
2,71 - 3,10	20	39	60	3,0	4 - 6 *	37,00
3,11 - 3,70	22	37	60	4,0	6	37,00
3,71 - 4,10	24	40	65	4,0	6	39,00
4,11 - 4,60	24	40	65	5,0	6	42,00
4,61 - 4,90	26	38	65	5,0	6	46,00
4,91 - 5,20	26	48	75	5,0	6	48,00
5,21 - 5,70	26	48	75	5,0	6	51,00
5,71 - 6,20	26	48	75	5,0 - 6,0	6	56,00
6,21 - 6,60	30	49	80	6,0	6	60,00
6,61 - 6,90	30	49	80	6,0 - 7,0	6	64,00
6,91 - 7,20	35	59	95	7,0	6	69,00
7,21 - 7,70	35	59	95	7,0	6	78,00
7,71 - 8,20	35	59	95	7,0 - 8,0	6	85,00
8,21 - 8,70	35	64	100	8,0	6	94,00
8,71 - 8,90	35	64	100	8,0 - 9,0	6	97,00
8,91 - 9,20	35	64	100	9,0	6	99,00
9,21 - 9,70	35	64	100	9,0	6	103,00
9,71 - 9,90	35	64	100	9,0 - 10,0	6	110,00
9,91 - 10,70	35	64	100	10,0	6	119,00
10,71 - 10,90	35	64	100	10,0 - 11,0	6	122,00
10,91 - 11,20	35	64	100	11,0	6	126,00
11,21 - 11,70	35	64	100	11,0	6	129,00
11,71 - 11,90	35	64	100	11,0 - 12,0	6	135,00
11,91 - 12,60	35	64	100	12,0	6	140,00
12,61 - 12,90	35	64	100	12,0 - 13,0	6	149,00
12,91 - 13,52	35	64	100	13,0	6	149,00
13,90 - 14,10	35	64	100	14,0	6	202,00
14,90 - 15,10	35	64	100	14,0	6	216,00
15,90 - 16,10	35	64	100	16,0	6	216,00
17,90 - 18,10	35	64	100	18,0	6	254,00

Mehrpreis für: - 3. Stelle nach dem Komma (Bsp. 2,955)  
Extra costs for: - 3rd place after comma (example 2,955)

- eingengte Toleranz +/- 0,001 mm  
- restricted tolerance +/- 0,001 mm

- Passungsreibahlen (Bsp. 5 P7)  
- Reamers for precise seats (example 5 P7)

+ 10% Aufschlag  
+ 10% surcharge

+ 10% Aufschlag  
+ 10% surcharge

+ 10% Aufschlag  
+ 10% surcharge

## VHM-HSC-Sackloch-Reibahlen mit Innenkühlung kurz

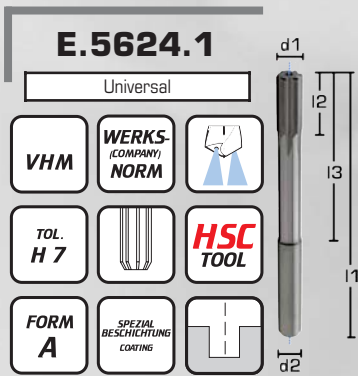

Artikel-Nr. Article-No.						E.5624.1
d1 H7	l2	l3	l1	d2	Zähne flutes	Stück piece
5,00	12	32	74	6,0	4	136,00
6,00	12	33	74	6,0	4	136,00
8,00	16	50	91	8,0	6	150,00
10,00	20	58	103	10,0	6	180,00
12,00	24	68	118	12,0	6	225,00
14,00	28	81	132	14,0	6	259,00

- Solid carbide HSC blind hole reamers with internal coolant short
- Rozwiertaki krótkie z węgla spiekane-go z chłodz. wew. do obróbki szybkościowej HSC do otw. nieprzelotowych
- Alesatori MD-HSC con fori lubrificanti per fori ciechi, serie corta
- Escariador para agujeros ciegos metal duro integral, serie corta con refrigeración interior para alta velocidad

## VHM-HSC-Sacklochreibahlen mit Innenkühlung kurz

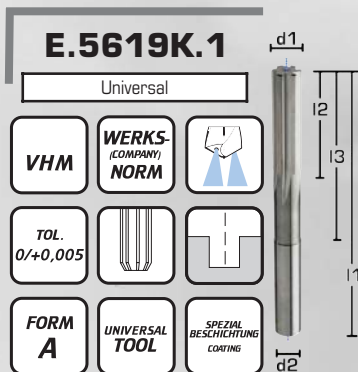

Artikel-Nr. Article-No.						E.5619K.1
d1 0/+0,005	l2	l3	l1	d2 h6	Zähne flutes	Stück piece
2,95 - 3,05	22	40	75	6,0	6	116,00
3,06 - 3,96	24	40	75	6,0	6	123,00
3,97 - 4,05	24	40	75	6,0	6	104,00
4,06 - 4,96	24	40	75	6,0	6	108,00
4,97 - 5,05	24	40	75	6,0	6	98,00
5,06 - 5,96	24	40	75	6,0	6	102,00
5,97 - 6,05	30	45	80	6,0	6	97,00
6,06 - 6,47	30	45	80	6,0	6	132,00
6,48 - 6,96	30	63	103	8,0	6	132,00
6,97 - 7,05	30	63	103	8,0	6	128,00
7,06 - 7,96	30	63	103	8,0	6	132,00
7,97 - 8,05	35	63	103	8,0	6	127,00
8,06 - 8,47	35	63	103	8,0	6	150,00
8,48 - 8,96	35	63	103	10,0	6	150,00
8,97 - 9,05	35	63	103	10,0	6	150,00
9,06 - 9,96	35	63	103	10,0	6	150,00
9,97 - 10,05	35	63	103	10,0	6	148,00
10,06 - 10,47	35	63	103	10,0	6	201,00
10,48 - 10,96	40	63	103	12,0	6	201,00
10,97 - 11,05	40	63	103	12,0	6	201,00
11,06 - 11,96	40	63	103	12,0	6	201,00
11,97 - 12,10	40	63	103	12,0	6	203,00

- Solid carbide HSC blind hole reamers with internal coolant short
- Rozwiertaki krótkie z węgla spiekane-go z chłodz. wew. do obróbki szybkościowej HSC do otwo. nieprzelotowych
- Alesatori MD-HSC con fori lubrificanti, serie corta
- Escariador para agujeros ciegos metal duro integral, serie corta con refrigeración interior para alta velocidad

- Gewindebohrer 1
- Bohren HSSE 2
- Bohren VHM 3
- Reiben HSSE 4
- Reiben VHM 5
- Frässtifte VHM 6
- Fräsen VHM 7
- WP-Werkzeuge 8
- Fräsen HSSE 9
- Sägen 10
- Lehren 11
- Nachschleifen 12
- Sonstiges 13

# VHM-Sackloch-Reibahlen kurz

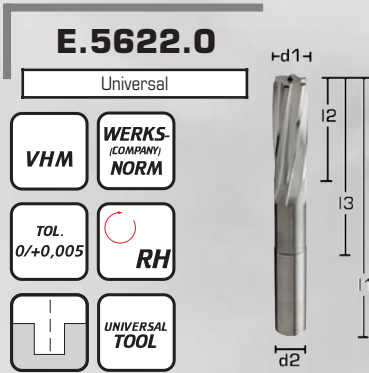

Solid carbide blind hole reamers short

Rozwiertaki krótkie z węgla spiekane-go do otworów nieprzelotowych

Alesatori MD per fori ciechi, serie corta

Escariador para agujeros ciegos metal duro integral, serie corta

\* = ab Ø 3,0 mm Zähnezahl 6

\* = starting from Ø 3,0 mm 6 flutes

Artikel-Nr. Article-No.						E.5622.0
d1 0/+0,005	l2	l3	l1	d2 h6	Zähne flutes	€ Stück piece
1,51 - 2,00	16	28	45	2,0	4	44,00
2,01 - 2,40	18	31	50	2,0 - 3,0	4	44,00
2,41 - 2,70	20	34	55	3,0	4	44,00
2,71 - 3,10	20	39	60	3,0	4 - 6*	47,00
3,11 - 3,70	22	37	60	4,0	6	47,00
3,71 - 4,10	24	40	65	4,0	6	49,00
4,11 - 4,60	24	40	65	5,0	6	53,00
4,61 - 4,90	26	38	65	5,0	6	58,00
4,91 - 5,20	26	48	75	5,0	6	60,00
5,21 - 5,70	26	48	75	5,0	6	64,00
5,71 - 6,20	26	48	75	5,0 - 6,0	6	71,00
6,21 - 6,60	30	49	80	6,0	6	76,00
6,61 - 6,90	30	49	80	6,0 - 7,0	6	80,00
6,91 - 7,20	35	59	95	7,0	6	87,00
7,21 - 7,70	35	59	95	7,0	6	98,00
7,71 - 8,20	35	59	95	7,0 - 8,0	6	107,00
8,21 - 8,70	35	64	100	8,0	6	118,00
8,71 - 8,90	35	64	100	8,0 - 9,0	6	123,00
8,91 - 9,20	35	64	100	9,0	6	124,00
9,21 - 9,70	35	64	100	9,0	6	129,00
9,71 - 9,90	35	64	100	9,0 - 10,0	6	138,00
9,91 - 10,70	35	64	100	10,0	6	149,00
10,71 - 10,90	35	64	100	10,0 - 11,0	6	154,00
10,91 - 11,20	35	64	100	11,0	6	158,00
11,21 - 11,70	35	64	100	11,0	6	162,00
11,71 - 11,90	35	64	100	11,0 - 12,0	6	169,00
11,91 - 12,60	35	64	100	12,0	6	176,00
12,61 - 12,90	35	64	100	12,0 - 13,0	6	187,00
12,91 - 13,52	35	64	100	13,0	6	187,00
13,90 - 14,10	35	64	100	14,0	6	254,00
14,90 - 15,10	35	64	100	14,0	6	271,00
15,90 - 16,10	35	64	100	16,0	6	278,00
17,90 - 18,10	35	64	100	18,0	6	319,00

## Aufpreis für Stirnverzahnung: Extra charge for end cut:

Ø	€	
	1 - 2 Stück 1 - 2 piece	ab 3 Stück starting from 3 pieces
2,95 - 6,05	21,00	18,00
6,06 - 18,10	28,00	24,00

## Bohrungsuntermaßtabelle für Reibahlen Prehole diameter chart for reamers:

< Ø 1 mm	> Ø 10 mm	> Ø 20	> Ø 30	< Ø 30
- 0,10	- 0,20	- 0,25	- 0,30	- 0,40

## VHM-Superfinish-Maschinenreibahlen kurz

**E.5632.0**

Universal

VHM

WERKS  
(COMPANY)  
NORM

TOL.  
H 7

FORM  
A

Solid carbide superfinish machine reamers short

Rozwiertaki maszynowe krótkie z węglika spiekanego do obróbki super-finiuszowej

Alesatori a macchina MD per super finitura, serie corta

Escariador de máquina en metal duro integral, serie corta para acabado fino

**Rt 1,6 - 3,2**

Artikel-Nr. Article-No.						<b>E.5632.0</b>
d1 H7	l2	l3	l1	d2 h6	Zähne flutes	€ Stück piece
2,00	18	28	50	3,0	4	<b>36,00</b>
3,00	27	37	60	3,0	4	<b>40,00</b>
4,00	27	37	80	6,0	4	<b>45,00</b>
5,00	30	40	80	6,0	6	<b>50,00</b>
6,00	30	50	80	6,0	6	<b>58,00</b>
8,00	35	50	80	8,0	6	<b>86,00</b>
10,00	40	60	90	10,0	6	<b>102,00</b>
12,00	45	60	90	12,0	6	<b>130,00</b>

## VHM-Maschinenreibahlen lang

**E.5620.0**

Universal

VHM

ähnl.  
DIN  
212

TOL.  
0/+0,005

FORM  
B

UNIVERSAL  
TOOL

Solid carbide machine reamers long

Rozwiertaki maszynowe długie z węglika spiekanego

Alesatori a macchina MD serie lunga

Escariador de máquina en metal duro integral, serie larga

Artikel-Nr. Article-No.					<b>E.5620.0</b>
d1 0/+0,005	l2	l1	d2	Zähne flutes	€ Stück piece
0,97 - 1,05	5	40	1,5	4	<b>24,50</b>
1,97 - 2,05	11	49	2,0	4	<b>21,80</b>
2,97 - 3,05	15	61	3,0	6	<b>24,10</b>
3,97 - 4,05	19	75	4,0	6	<b>31,20</b>
4,97 - 5,05	23	86	5,0	6	<b>39,50</b>
5,97 - 6,05	26	93	6,0	6	<b>43,00</b>
6,97 - 6,99	31	109	8,0	6	<b>56,00</b>
7,01 - 7,05	31	109	8,0	6	<b>61,00</b>
7,97 - 8,05	33	117	8,0	6	<b>65,00</b>
8,97 - 9,05	36	125	10,0	6	<b>81,00</b>
9,97 - 10,05	38	133	10,0	6	<b>94,00</b>
10,97 - 11,05	41	142	12,0	6	<b>98,00</b>
11,97 - 12,05	44	151	12,0	6	<b>122,00</b>

Bohrungsuntermaßtabelle für Reibahlen *Prehole diameter chart for reamers:*

< ø 1 mm	> ø 10 mm	> ø 20	> ø 30
- 0,10	- 0,20	- 0,25	- 0,30

Gewindebohrer	1
Bohren HSSE	2
Bohren VHM	3
Reiben HSSE	4
Reiben VHM	5
Frässtifte VHM	6
Fräsen VHM	7
WP-Werkzeuge	8
Fräsen HSSE	9
Sägen	10
Lehren	11
Nachschleifen	12
Sonstiges	13

# VHM-Maschinenreibahlen lang

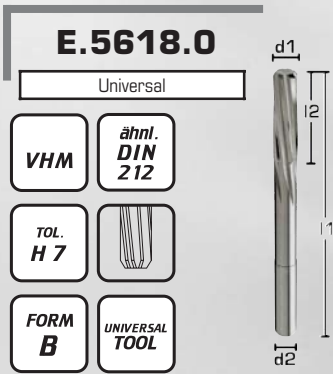

**E.5618.0**

Universal





VHM

ähnl. DIN 212

TOL. H 7

FORM B

UNIVERSAL TOOL

-  Solid carbide machine reamers long
-  Rozwiertaki maszynowe długie z węglika spiekanego
-  Alesatori a macchina MD serie lunga
-  Escariador de máquina en metal duro integral, serie larga

\* = Auslaufartikel  
 \* = no future production anymore

Artikel-Nr. Article-No.					E.5618.0	Artikel-Nr. Article-No.					E.5618.0
d1 H7	l2	l1	d2	Zähne flutes	€ Stück piece	d1 H7	l2	l1	d2	Zähne flutes	€ Stück piece
1,00	5	40	1,0	4	14,50	4,60	21	80	4,6	4	25,50
1,10	7	40	1,1	4	14,50	4,70	21	80	4,7	4	25,50
1,20	7	40	1,2	4	14,50	4,80	23	86	4,8	6	28,00
1,30	7	40	1,3	4	14,50	4,90	23	86	4,9	6	28,00
1,40	8	40	1,4	4	14,50	5,00	23	86	5,0	6	28,00
1,50	8	40	1,5	4	14,50	5,10	23	86	5,1	6	28,00
1,60	9	43	1,6	4	14,50	5,20	23	86	5,2	6	28,00
1,70	10	46	1,7	4	14,50	5,30	23	86	5,3	6	28,00
1,80	10	46	1,8	4	14,50	5,40	26	93	5,4	6	32,00
1,90	10	46	1,9	4	14,00	5,50	26	93	5,5	6	32,00
2,00	11	49	2,0	4	14,00	5,60	26	93	5,6	6	36,00
2,10	11	49	2,1	4	14,00	5,70	26	93	5,7	6	36,00
2,20	12	53	2,2	4	14,00	5,80	26	93	5,8	6	36,00
2,30	12	53	2,3	4	15,00	5,90	26	93	5,9	6	36,00
2,40	14	54	2,4	4	17,00	6,00	26	93	6,0	6	36,00
2,50	14	57	2,5	4	17,00	6,50	28	101	6,5	6	48,00
2,60	14	57	2,6	4	17,00	7,00	31	109	7,0	6	52,00
2,70	15	61	2,7	4	18,50	7,50	31	109	7,5	6	56,00
2,80	15	61	2,8	4	18,50	8,00	33	117	8,0	6	57,00
2,90	15	61	2,9	4	18,50	8,50	33	117	8,5	6	63,00
3,00	15	61	3,0	4	18,50	9,00	36	125	9,0	6	64,00
3,10	16	65	3,1	4	19,60	9,50	36	125	9,5	6	72,00
3,20	16	65	3,2	4	19,60	10,00	38	133	10,0	6	74,00
3,30	16	65	3,3	4	19,60	10,50	38	133	10,5	6	80,00
3,40	18	70	3,4	4	19,60	11,00	41	142	11,0	6	81,00
3,50	18	70	3,5	4	19,60	11,50	41	142	11,5	6	90,00
3,60	18	70	3,6	4	19,60	12,00	44	151	12,0	6	93,00
3,70	18	70	3,7	4	19,60	12,50	44	151	12,5	6	93,00
3,80	19	75	3,8	4	22,50	13,00	44	151	13,0	6	128,00
3,90	19	75	3,9	4	22,50						
4,00	19	75	4,0	4	22,50						
4,10	19	75	4,1	4	22,50						
4,20	19	75	4,2	4	22,50						
4,30	21	80	4,3	4	25,50						
4,40	21	80	4,4	4	25,50						
4,50	21	80	4,5	4	25,50						

## VHM-HSC-Reibahlen mit Kühlkanälen in den Nuten lang

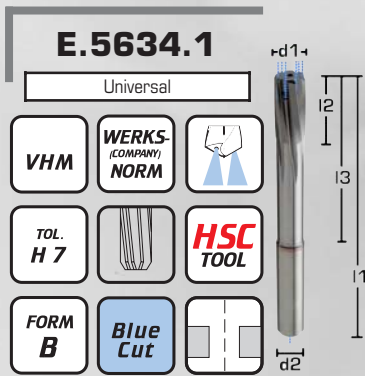

Artikel-Nr. Article-No.						E.5634.1
d1 H7	l2	l3	l1	d2	Zähne flutes	Stück piece
5,00	12	32	74	6,0	4	148,00
6,00	12	33	74	6,0	4	148,00
8,00	16	50	91	8,0	6	168,00
10,00	20	58	103	10,0	6	197,00
12,00	24	68	118	12,0	6	249,00
14,00	28	81	132	14,0	6	289,00

- Solid carbide HSC reamers with coolant system in the flutes long
- Rozwiertaki długie z węglika spiekane-go do obróbki szybkościowej HSC z chłodz. wew. w ostrzach
- Alesatori MD-HSC con fori lubrificanti lungo i taglienti
- Escariador en metal duro integral con refrigeración interior en las ranuras, serie larga para alta velocidad

Für Durchgangsbohrungen  
For through holes

## VHM-HSC-Reibahlen mit Kühlkanälen in den Nuten lang

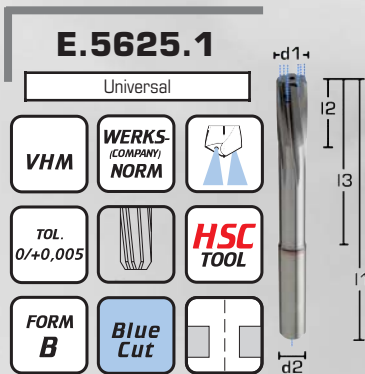

Artikel-Nr. Article-No.						E.5625.1
d1 0/+0,005	l2	l3	l1	d2	Zähne flutes	Stück piece
4,80 - 5,15	12	32	74	6,0	4	178,00
5,16 - 5,79	12	32	74	6,0	4	217,00
5,80 - 6,15	12	33	74	6,0	4	217,00
6,16 - 6,79	16	49	91	8,0	4	248,00
6,80 - 7,15	16	49	91	8,0	4	248,00
7,16 - 7,69	16	49	91	8,0	6	248,00
7,70 - 8,15	16	50	91	8,0	6	248,00
8,16 - 8,69	20	57	103	10,0	6	292,00
8,70 - 9,15	20	57	103	10,0	6	292,00
9,16 - 9,59	20	57	103	10,0	6	292,00
9,60 - 10,15	20	58	103	10,0	6	292,00
10,16 - 10,59	24	67	118	12,0	6	368,00
10,60 - 11,15	24	67	118	12,0	6	368,00
11,16 - 11,59	24	67	118	12,0	6	368,00
11,60 - 12,15	24	68	118	12,0	6	368,00
12,16 - 12,70	28	81	132	14,0	6	425,00
12,71 - 13,15	28	81	132	14,0	6	425,00
13,16 - 13,59	28	81	132	14,0	6	425,00
13,60 - 14,15	28	81	132	14,0	6	425,00

- Solid carbide HSC reamers with coolant system in the flutes long
- Rozwiertaki długie z węglika siekanego do obróbki szybkościowej HSC z chłodzeniem wewnętrznym w ostrzach
- Alesatori MD-HSC con fori lubrificanti lungo i taglienti
- Escariador en metal duro integral con refrigeración interior en las ranuras, serie larga para alta velocidad

Für Durchgangsbohrungen  
For through holes

- Gewindebohrer 1
- Bohren HSSE 2
- Bohren VHM 3
- Reiben HSSE 4
- Reiben VHM 5
- Frässtifte VHM 6
- Fräsen VHM 7
- WP-Werkzeuge 8
- Fräsen HSSE 9
- Sägen 10
- Lehren 11
- Nachschleifen 12
- Sonstiges 13



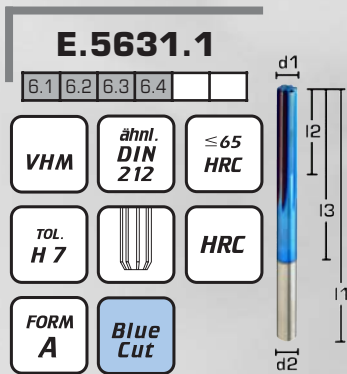

# VHM-HRC/NC-Maschinenreibahlen

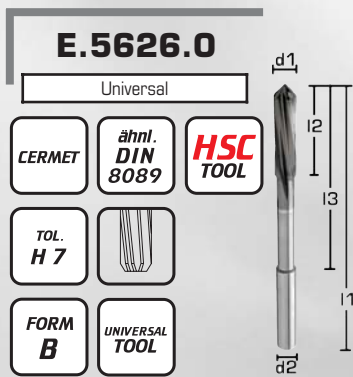

- Solid carbide HRC/NC reamers
- Rozwiertaki z węgla spiekane go do materiałów utwardzanych do 65 HRC do maszyn CNC
- Alesatori MD-HRC/NC a macchina
- Escariador de máquina NC en metal duro integral para alta dureza

Artikel-Nr.		Article-No.		E.5631.1		Artikel-Nr.		Article-No.		E.5631.1		Artikel-Nr.		Article-No.		E.5631.1						
d1 H7	l2	l3	l1	d2	Zähne flutes	€ St. pc.	d1 H7	l2	l3	l1	d2	Zähne flutes	€ St. pc.	d1 H7	l2	l3	l1	d2	Zähne flutes	€ St. pc.		
0,98	6	16	50	4,0	3	44,00	4,00	27	37	80	4,0	4	51,00	7,50	31	67	109	8,0	6	6	77,00	
0,99	6	16	50	4,0	3	44,00	4,01	21	43	77	4,0	4	51,00	7,60	31	67	109	8,0	6	6	77,00	
1,00	6	16	50	4,0	3	44,00	4,02	21	43	77	4,0	4	51,00	7,70	33	75	117	8,0	6	6	77,00	
1,01	6	16	50	4,0	3	44,00	4,03	21	43	77	4,0	4	51,00	7,80	33	75	117	8,0	6	6	77,00	
1,02	6	16	50	4,0	3	44,00	4,10	21	40	82	6,0	6	62,00	7,90	33	75	117	8,0	6	6	77,00	
1,03	9	16	50	4,0	3	44,00	4,20	21	40	82	6,0	6	62,00	7,97	33	75	117	8,0	6	6	77,00	
1,48	9	16	50	4,0	3	51,00	4,30	23	40	82	6,0	6	62,00	7,98	33	75	117	8,0	6	6	77,00	
1,49	9	16	50	4,0	3	51,00	4,40	23	40	82	6,0	6	62,00	7,99	33	75	117	8,0	6	6	77,00	
1,50	9	16	50	4,0	3	51,00	4,50	23	40	82	6,0	6	62,00	8,00	35	50	117	8,0	6	6	77,00	
1,51	9	16	50	4,0	3	51,00	4,60	23	40	82	6,0	6	62,00	8,01	33	75	117	8,0	6	6	77,00	
1,52	9	16	50	4,0	3	51,00	4,70	23	40	82	6,0	6	62,00	8,02	33	75	117	8,0	6	6	77,00	
1,60	10	16	50	4,0	3	51,00	4,80	26	51	93	6,0	6	62,00	8,03	33	75	117	8,0	6	6	77,00	
1,70	10	16	50	4,0	3	51,00	4,90	26	51	93	6,0	6	62,00	8,10	33	71	117	10,0	6	6	95,00	
1,80	11	16	50	4,0	3	51,00	4,97	26	51	93	6,0	6	62,00	8,20	33	71	117	10,0	6	6	95,00	
1,90	11	16	50	4,0	3	51,00	4,98	26	51	93	6,0	6	62,00	8,30	33	71	117	10,0	6	6	95,00	
1,97	12	16	50	4,0	4	51,00	4,99	26	51	93	6,0	6	62,00	8,40	33	71	117	10,0	6	6	95,00	
1,98	12	16	50	4,0	4	51,00	5,00	30	40	80	6,0	6	62,00	8,50	33	71	117	10,0	6	6	95,00	
1,99	12	16	50	4,0	4	51,00	5,01	26	51	93	6,0	6	62,00	8,60	33	71	117	10,0	6	6	95,00	
2,00	18	28	50	3,0	4	51,00	5,02	26	51	93	6,0	6	62,00	8,70	36	79	125	10,0	6	6	95,00	
2,01	12	16	50	4,0	4	51,00	5,03	26	51	93	6,0	6	62,00	8,80	36	79	125	10,0	6	6	95,00	
2,02	12	16	50	4,0	4	51,00	5,10	26	51	93	6,0	6	62,00	8,90	36	79	125	10,0	6	6	95,00	
2,03	12	16	50	4,0	4	51,00	5,20	26	51	93	6,0	6	62,00	9,00	36	79	125	10,0	6	6	95,00	
2,10	12	16	50	4,0	4	51,00	5,30	26	51	93	6,0	6	62,00	9,10	36	79	125	10,0	6	6	95,00	
2,20	13	16	50	4,0	4	51,00	5,40	26	51	93	6,0	6	62,00	9,20	36	79	125	10,0	6	6	95,00	
2,30	13	16	50	4,0	4	51,00	5,50	26	51	93	6,0	6	62,00	9,30	36	79	125	10,0	6	6	95,00	
2,40	16	26	60	4,0	4	51,00	5,60	26	51	93	6,0	6	62,00	9,40	36	79	125	10,0	6	6	95,00	
2,50	16	26	60	4,0	4	51,00	5,70	26	51	93	6,0	6	62,00	9,50	36	79	125	10,0	6	6	95,00	
2,60	16	26	60	4,0	4	51,00	5,80	26	51	93	6,0	6	62,00	9,60	36	79	125	10,0	6	6	95,00	
2,70	17	30	64	4,0	4	51,00	5,90	26	51	93	6,0	6	62,00	9,70	38	87	133	10,0	6	6	95,00	
2,80	17	30	64	4,0	4	51,00	5,97	26	51	93	6,0	6	62,00	9,80	38	87	133	10,0	6	6	95,00	
2,90	17	30	64	4,0	4	51,00	5,98	26	51	93	6,0	6	62,00	9,90	38	87	133	10,0	6	6	95,00	
2,97	17	30	64	4,0	4	51,00	5,99	26	51	93	6,0	6	62,00	9,97	41	87	133	10,0	6	6	95,00	
2,98	17	30	64	4,0	4	51,00	6,00	30	50	80	6,0	6	62,00	9,98	41	87	133	10,0	6	6	95,00	
2,99	17	30	64	4,0	4	51,00	6,01	26	51	93	6,0	6	62,00	9,99	41	87	133	10,0	6	6	95,00	
3,00	27	37	60	3,0	4	51,00	6,02	26	51	93	6,0	6	62,00	10,00	40	60	133	10,0	6	6	95,00	
3,01	17	30	64	4,0	4	51,00	6,03	26	51	93	6,0	6	62,00	10,01	41	87	133	10,0	6	6	95,00	
3,02	17	30	64	4,0	4	51,00	6,10	26	59	101	8,0	6	77,00	10,02	41	87	133	10,0	6	6	95,00	
3,03	17	30	64	4,0	4	51,00	6,20	26	59	101	8,0	6	77,00	10,03	41	87	133	10,0	6	6	95,00	
3,10	18	34	68	4,0	4	51,00	6,30	26	59	101	8,0	6	77,00	10,04	41	87	133	10,0	6	6	95,00	
3,20	18	34	68	4,0	4	51,00	6,40	26	59	101	8,0	6	77,00	10,05	41	87	133	10,0	6	6	95,00	
3,30	18	34	68	4,0	4	51,00	6,50	26	59	101	8,0	6	77,00	11,97	44	99	150	12,0	6	6	125,00	
3,40	20	40	74	4,0	4	51,00	6,60	26	59	101	8,0	6	77,00	11,98	44	99	150	12,0	6	6	125,00	
3,50	20	40	74	4,0	4	51,00	6,70	26	59	101	8,0	6	77,00	11,99	44	99	150	12,0	6	6	125,00	
3,60	20	40	74	4,0	4	51,00	6,80	31	67	109	8,0	6	77,00	12,00	45	60	150	12,0	6	6	125,00	
3,70	20	40	74	4,0	4	51,00	6,90	31	67	109	8,0	6	77,00	12,01	44	99	150	12,0	6	6	125,00	
3,80	21	43	77	4,0	4	51,00	7,00	31	67	109	8,0	6	77,00	12,02	44	99	150	12,0	6	6	125,00	
3,90	21	43	77	4,0	4	51,00	7,10	31	67	109	8,0	6	77,00	12,03	44	99	150	12,0	6	6	125,00	
3,97	21	43	77	4,0	4	51,00	7,20	31	67	109	8,0	6	77,00	12,04	44	99	150	12,0	6	6	125,00	
3,98	21	43	77	4,0	4	51,00	7,30	31	67	109	8,0	6	77,00									
3,99	21	43	77	4,0	4	51,00	7,40	31	67	109	8,0	6	77,00									



-  Cermet NC machine reamers
-  Rozwiertaki maszynowe cermetowe do obróbki szybkościowej HSC do maszyn CNC
-  Alesatori a macchina in cermet NC
-  Escariador de máquina NC en Cermet

ab  $\varnothing$  11 mm mit Cermetkopf und Stahlschaft  
from  $\varnothing$  11 mm with Cermet head and steel shank

Artikel-Nr. Article-No.						E.5626.0
d1 H7	l2	l3	l1	d2	Zähne flutes	€ Stück piece
3,00	15	41	60	3,0	4	63,00
3,50	18	44	60	4,0	4	69,00
4,00	19	43	75	4,0	4	70,00
4,50	21	47	75	5,0	4	84,00
5,00	23	52	85	5,0	4	88,00
5,50	26	57	93	6,0	4	99,00
6,00	26	57	93	6,0	4	100,00
6,50	28	63	101	8,0	6	113,00
7,00	31	69	109	8,0	6	115,00
7,50	33	69	109	8,0	6	122,00
8,00	33	75	117	8,0	6	121,00
8,50	36	75	117	8,0	6	130,00
9,00	38	81	120	10,0	6	133,00
9,50	38	81	125	10,0	6	153,00
10,00	38	87	133	10,0	6	146,00
11,00	41	96	142	10,0	6	164,00
12,00	44	105	151	10,0	6	169,00
13,00	44	105	151	10,0	6	207,00
14,00	47	110	160	14,0	6	223,00
15,00	50	112	162	14,0	6	259,00
16,00	53	120	170	14,0	6	291,00
17,00	54	123	175	14,0	6	324,00
18,00	56	130	182	14,0	6	360,00
19,00	58	131	189	16,0	6	423,00
20,00	60	137	196	16,0	6	448,00

- Gewindebohrer 1
- Bohren HSSE 2
- Bohren VHM 3
- Reiben HSSE 4
- Reiben VHM 5
- Frässtifte VHM 6
- Fräsen VHM 7
- WP-Werkzeuge 8
- Fräsen HSSE 9
- Sägen 10
- Lehren 11
- Nachschleifen 12
- Sonstiges 13

Bohrungsuntermaßtabelle für Reibahlen *Prehole diameter chart for reamers:*

< $\varnothing$ 1 mm	> $\varnothing$ 10 mm	> $\varnothing$ 20	> $\varnothing$ 30	< $\varnothing$ 30
- 0,10	- 0,20	- 0,25	- 0,30	- 0,40

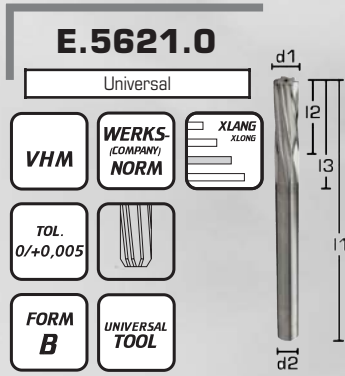

Solid carbide reamers XL

Rozwiertaki z węgla spiekanego bardzo długie

Alesatori MD, XL

Escariador de máquina en metal duro integral, serie extra larga

Artikel-Nr. Article-No.						E.5621.0 € Stück piece
d1 0/+0,005	l2	l3	l1	d2 h6	Zähne flutes	
2,95 - 3,05	20	79	100	3,0	6	72,00
2,95 - 3,05	20	129	150	3,0	6	98,00
3,95 - 4,05	24	75	100	4,0	6	64,00
3,95 - 4,05	24	125	150	4,0	6	98,00
4,95 - 5,05	26	73	100	5,0	6	79,00
4,95 - 5,05	26	123	150	5,0	6	98,00
5,95 - 6,05	26	73	100	6,0	6	86,00
5,95 - 6,05	26	123	150	6,0	6	101,00
6,95 - 7,05	35	115	150	7,0	6	113,00
7,90 - 8,10	35	115	150	8,0	6	140,00
8,90 - 9,10	35	115	150	9,0	6	163,00
9,90 - 10,10	35	115	150	10,0	6	181,00
10,90 - 11,10	35	115	150	11,0	6	207,00
11,90 - 12,10	35	115	150	12,0	6	230,00
12,90 - 13,10	35	115	150	13,0	6	242,00
13,90 - 14,10	35	115	150	13,0	6	258,00
14,90 - 15,10	35	115	150	14,0	6	278,00
15,90 - 16,10	35	115	150	16,0	6	294,00

Zwischenmaße zum nächsthöheren Preis! *Intermediate sizes to the next higher price!*

Bohrungsuntermaßtabelle für Reibahlen *Prehole diameter chart for reamers:*

< ø 1 mm	> ø 10 mm	> ø 20	> ø 30	< ø 30
- 0,10	- 0,20	- 0,25	- 0,30	- 0,40

# HM-bestückte-Maschinenreibahlen kurze Schneide

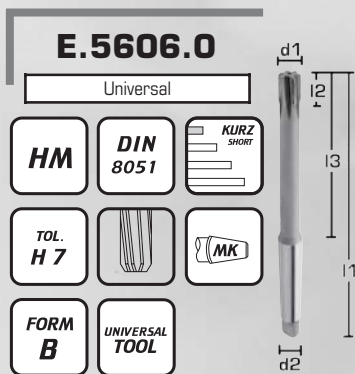

Artikel-Nr. Article-No.						E.5606.0 € Stück piece
d1 H7	l2	l3	l1	d2	Zähne flutes	
16,00	22	130	210	2	6	60,00
17,00	22	134	214	2	6	67,00
18,00	22	139	219	2	6	64,00
19,00	22	143	223	2	6	68,00
20,00	22	148	228	2	6	67,00
21,00	25	152	232	2	6	73,00
22,00	25	157	237	2	6	73,00
23,00	25	161	241	2	6	90,00
24,00	25	169	268	3	8	93,00
25,00	25	169	268	3	8	93,00
26,00	25	174	273	3	8	101,00
27,00	30	178	277	3	8	120,00
28,00	30	178	277	3	8	175,00
29,00	30	182	281	3	8	120,00
30,00	30	182	281	3	8	120,00
31,00	30	186	285	3	8	132,00
32,00	30	193	317	4	8	132,00
34,00	30	197	321	4	8	156,00
35,00	30	197	321	4	8	156,00
36,00	30	201	325	4	8	171,00
38,00	30	205	329	4	8	171,00
40,00	30	205	329	4	8	180,00

- Carbide tipped machine reamers short flutes
- Rozwiertaki maszynowe krótkie z chwytem ze stali narzędziowej i ostrzem z węgla spiekanego
- Alesatori a macchina con placchette in MD, taglienti corti
- Escariador de máquina con plaquitas de metal duro, serie corta

Gewindebohrer	1
Bohren HSSE	2
Bohren VHM	3
Reiben HSSE	4
Reiben VHM	5
Frässtifte VHM	6
Fräsen VHM	7
WP-Werkzeuge	8
Fräsen HSSE	9
Sägen	10
Lehren	11
Nachschleifen	12
Sonstiges	13

Bohrungsuntermaßtabelle für Reibahlen *Prehole diameter chart for reamers:*

< ø 1 mm	> ø 10 mm	> ø 20	> ø 30	< ø 30
- 0,10	- 0,20	- 0,25	- 0,30	- 0,40

## HM-bestückte-Maschinenreibahlen lange Schneide

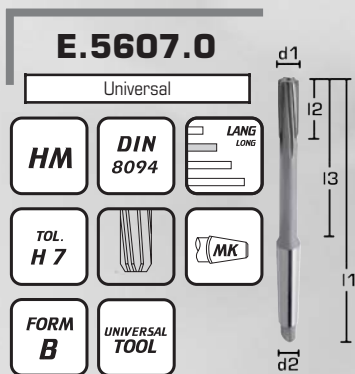

 Carbide tipped machine reamers long flutes

 Rozwiertaki maszynowe długie z chwytem ze stali narzędziowej i ostrzem z węgla spiekanego

 Alesatori a macchina con placchette in MD, taglianti lunghi

 Escariador de máquina con plaquitas de metal duro, serie larga





Artikel-Nr. Article-No.						E.5607.0 € Stück piece
d1 H7	l2	l3	l1	d2	Zähne flutes	
16,00	45	130	210	2	6	80,00
17,00	56	134	214	2	6	87,00
18,00	56	139	219	2	6	82,00
19,00	56	143	223	2	6	97,00
20,00	56	148	228	2	6	91,00
21,00	56	152	232	2	6	105,00
22,00	56	157	237	2	6	105,00
23,00	56	161	241	2	6	129,00
24,00	70	169	268	3	8	129,00
25,00	70	169	268	3	8	129,00
26,00	70	174	273	3	8	142,00
27,00	70	178	277	3	8	167,00
28,00	70	178	277	3	8	167,00
29,00	70	182	281	3	8	168,00
30,00	70	182	281	3	8	168,00
31,00	70	186	285	3	8	192,00
32,00	70	193	317	4	8	192,00
34,00	70	197	321	4	8	223,00
35,00	70	197	321	4	8	223,00
36,00	70	201	325	4	8	249,00
38,00	70	205	329	4	8	249,00
40,00	70	205	329	4	8	257,00

Bohrungsuntermaßtabelle für Reibahlen *Prehole diameter chart for reamers:*

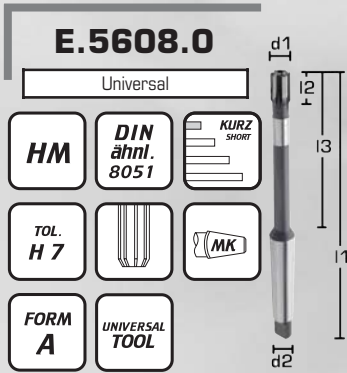
< ø 1 mm	> ø 10 mm	> ø 20	> ø 30	< ø 30
- 0,10	- 0,20	- 0,25	- 0,30	- 0,40

## HM-bestückte-Maschinendehnreibahlen kurz





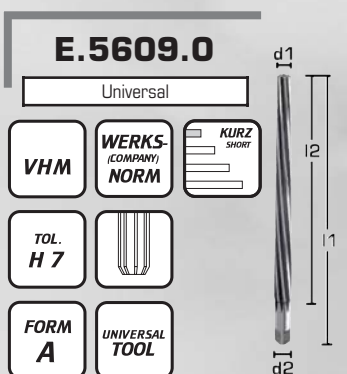

-  Carbide tipped machine reamers short
-  Rozwiertaki maszynowe krótkie z chwytem ze stali narzędziowej i ostrzem z węglika spiekanego
-  Alesatori a macchina con placchette in MD, serie lunga
-  Escariador expansible de máquina con plaquitas de metal duro, serie corta

Artikel-Nr. Article-No.						E.5608.0
d1 H7	l2	l3	l1	d2	Zähne flutes	€ Stück piece
16,00	22	130	210	2	6	253,00
17,00	22	134	214	2	6	268,00
18,00	22	139	219	2	6	260,00
19,00	22	143	223	2	6	274,00
20,00	22	148	228	2	6	262,00
22,00	25	157	237	2	6	276,00
24,00	25	169	268	3	8	336,00
25,00	25	169	268	3	8	336,00
26,00	25	174	273	3	8	376,00
28,00	30	178	277	3	8	396,00
30,00	30	182	281	3	8	409,00
32,00	30	193	317	4	8	470,00
34,00	30	197	321	4	8	562,00
35,00	30	197	321	4	8	562,00
36,00	30	201	325	4	8	577,00
38,00	30	205	329	4	8	591,00
40,00	30	205	329	4	8	594,00

## VHM-Kegelreibahle 1:50



-  Solid carbide conical reamers 1:50
-  Rozwiertaki z węglika spiekanego stożkowe, zbieżność 1:50
-  Alesatori conici 1:50 MD
-  Escariadores cónicos de metal duro 1:50

Artikel-Nr. Article-No.						E.5609.0
d1	l2	l1	d2	Zähne flutes	€ Stück piece	
1,50	37	57	2,50	3	104,00	
2,00	48	68	2,50	4	108,00	
3,00	58	80	3,15	5	126,00	
4,00	68	93	4,00	5	138,00	
5,00	73	100	5,00	5	160,00	
6,00	105	135	6,30	6	215,00	
8,00	145	180	8,00	6	270,00	

Bohrungsuntermaßtabelle für Reibahlen *Prehole diameter chart for reamers:*

< ø 1 mm	> ø 10 mm	> ø 20	> ø 30	< ø 30
- 0,10	- 0,20	- 0,25	- 0,30	- 0,40

- Gewindebohrer 1
- Bohren HSSE 2
- Bohren VHM 3
- Reiben HSSE 4
- Reiben VHM 5
- Frässtifte VHM 6
- Fräsen VHM 7
- WP-Werkzeuge 8
- Fräsen HSSE 9
- Sägen 10
- Lehren 11
- Nachschleifen 12
- Sonstiges 13

## Einsatzrichtwerte *Estimated values for use*

VR / fz	Vorschub (mm/U) <i>feed</i>										
	< Ø 2	< Ø 4	< Ø 6	< Ø 8	< Ø 10	< Ø 12	< Ø 14	< Ø 18	< Ø 22	< Ø 26	< Ø 30
<b>1</b>	0,020	0,040	0,050	0,060	0,080	0,090	0,105	0,130	0,160	0,185	0,215
<b>2</b>	0,025	0,050	0,060	0,080	0,090	0,100	0,115	0,145	0,175	0,200	0,230
<b>3</b>	0,030	0,060	0,080	0,100	0,120	0,140	0,165	0,205	0,250	0,290	0,335
<b>4</b>	0,040	0,080	0,100	0,125	0,160	0,180	0,210	0,265	0,320	0,375	0,430
<b>5</b>	0,050	0,100	0,120	0,160	0,200	0,220	0,260	0,330	0,395	0,465	0,530
<b>6</b>	0,060	0,120	0,160	0,200	0,250	0,280	0,330	0,410	0,500	0,590	0,680
<b>7</b>	0,080	0,160	0,200	0,250	0,310	0,340	0,400	0,505	0,610	0,710	0,810
<b>8</b>	0,100	0,200	0,250	0,320	0,400	0,440	0,520	0,650	0,790	0,920	1,050

Materialgruppe <i>material group</i>	VHM-Reibahlen <i>VHM-reamers</i>				VHM-Kegelsenker <i>VHM-countersink</i>			
	blank <i>uncoated</i>		beschichtet <i>coated</i>		Vc (m/min)	Vf (mm/min)		
	Vc (m/min)	VR / fz	Vc (m/min)	VR / fz		< Ø 10	< Ø 20	< Ø 31
<b>1.1</b>	20 - 25	7	18 - 24	8	50	340	320	220
<b>1.2</b>	15 - 20	7	18 - 24	8	45	500	245	170
<b>1.3</b>	10 - 15	5	12 - 16	6	35	220	110	75
<b>2.1</b>	6 - 10	3	8 - 12	3	25	120	60	40
<b>2.2</b>	6 - 10	3	8 - 12	3				
<b>3.1</b>	30 - 40	7	30 - 35	7	25	130	70	45
<b>3.2</b>	20 - 25	6	30 - 35	7				
<b>3.3</b>	15 - 20	6	18 - 24	7				
<b>3.4</b>	15 - 20	6	18 - 24	7				
<b>4.1</b>	30 - 35	8	33 - 40	8	50	400	200	140
<b>4.2</b>	20 - 30	7	25 - 32	7				
<b>4.3</b>	18 - 24	7	22 - 28	7				
<b>4.4</b>	20 - 30	7	24 - 32	7				
<b>4.5</b>	18 - 24	7	22 - 30	7				
<b>4.6</b>	18 - 24	7	22 - 30	7	25	800	400	270
<b>4.7</b>	15 - 20	8	18 - 24	8				
<b>4.8</b>					100	1600	800	500
<b>4.9</b>								
<b>5.1</b>	6 - 10	5	8 - 14	6	25	120	60	40
<b>5.2</b>	4 - 6	3	6 - 8	4	20	100	40	30
<b>6.1</b>			8	4	30	180	80	60
<b>6.2</b>			8	3				
<b>6.3</b>			5	2				
<b>6.4</b>			5	2				

5.19 Reibahlen mit IK blank: Vc und fz + 50 % *Reamers with internal coolant uncoated: Vc and fz + 50 %*  
 Reibahlen mit IK beschichtet: Vc und fz +100 % *Reamers with internal coolant coated: Vc and fz +100 %*